

C a l i b r a t i o n S t r u c t u r e B u i l d i n g M a n u a l

Georgios Louizis, Dimitrios Zarpalas & Petros Daras

**Visual Computing Lab
Information Technologies Institute
the Centre for Research & Technology – Hellas**

**this work was supported by
the EU funded FP7 project
R E P L A Y
(contract no: 601170)**

Calibration Structure Building Manual

What you will need to build the calibration structure:

- 4 x IKEA Jattene cardboard boxes (Article Number : 600.471.51)
- Cardboard marker
- Markers.pdf file
- Computer
- Printer
- 32 x A4 plain paper sheets
- Metal ruler
- Paper knife
- Paper glue.

ATTENTION: Building imperfections will affect the calibration results. Please follow the instructions closely and complete each step accurately.

STEP1: Preparing the boxes.

Assemble the cardboard boxes. After assembling, each box will look like this:



Image 1 An IKEA Jattene box assembled.

Take one box and name its side faces with the letters A, B, C and D, starting from a large face and moving right wise.



Image 2 The 4 side faces of the first box with their names marked on them.

The first marked box should look like this:



Image 3 The ABCD box with the A and D faces visible.

Repeat the same procedure for the rest of the boxes, starting ALWAYS from a large side and moving right wise. The letters for the next three boxes have to be:

- Second box: G,H,I and J
- Third box: K, L, M and N
- Fourth box: O, P, Q and R.

Once all 4 boxes have been assembled and their faces named, you can proceed to next step.

STEP2: Preparing the markers.

Print the Markers.pdf file on the A4 paper sheets. Be careful to print them in portrait orientation with NO scaling (i.e. in actual size with no shrinking or expansion). A printed marker should look like this:



Image 4 A printed marker.

In order to check that the markers were printed correctly, measure the distance between the two corner dots. That distance has to be exactly 13cm. These dots are highlighted in the following image:

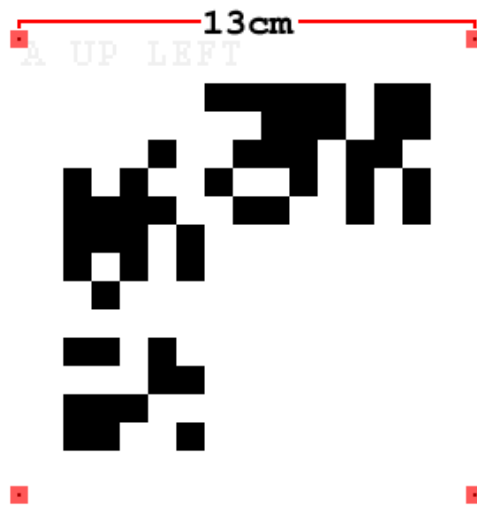

Image 5 A marker with the 4 corner dots highlighted.

Cut the marker off the A4 sheet by using the 4 corner dots as guides. The 4 cutting lines are highlighted in the following image:



Image 6 A marker with cutting guide lines highlighted.

The result is a 13cm x 13cm square paper marker. You can notice that the marker's unique name and position is printed on the marker's top edge in light gray. This will help you distinguish between them and glue them properly during the next step.



Image 7 A marker with its name and position highlighted.

Once all 32 markers have been cut, you can proceed to next step.

STEP3: Placing markers on boxes.

Starting from face A of the ABCD box, glue the A UP LEFT marker on the upper left corner aligned with the face's edges. Pay attention so that the marker is rotated correctly before gluing, i.e. its name and position are situated on the marker's upper edge.

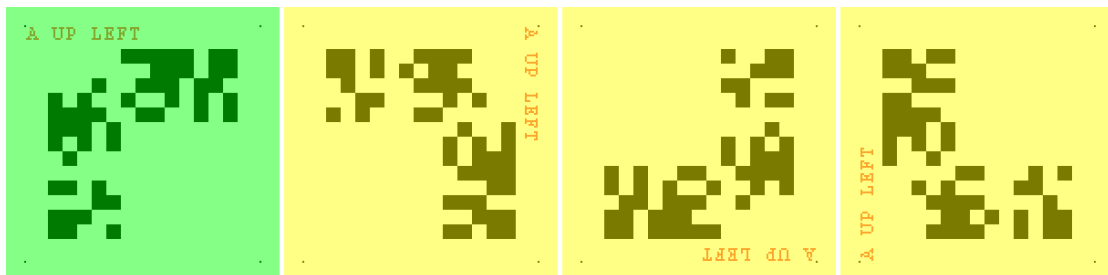

Image 8 The marker highlighted with green is correctly rotated. The other three denote wrong rotations.

Proceed with gluing the A DOWN RIGHT marker on the lower right corner of face A. The result should look like this:

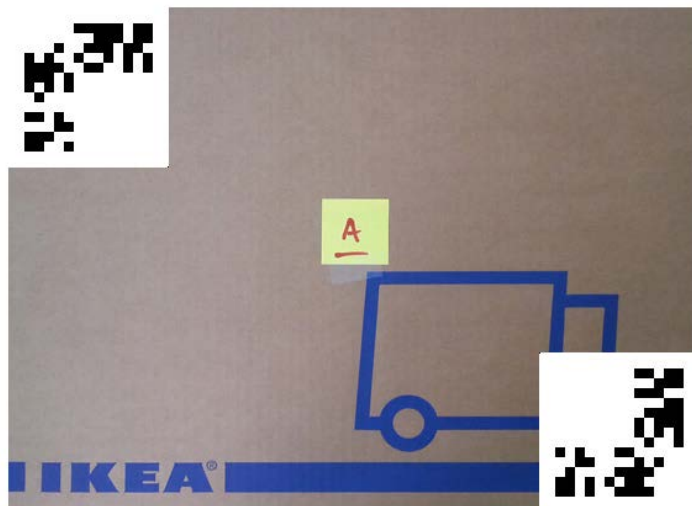

Image 9 Face A of box ABCD with the two markers in place.

Continue with the markers B UP LEFT and B DOWN RIGHT on face B. Then proceed attaching the corresponding markers on faces C and D of the first box. Once you are done, the ABCD box should look like this:



Image 10 The side faces of box ABCD with the corresponding markers in place.



Image 11 The ABCD box with the A and D faces visible.

Repeat the same procedure for the boxes GHIJ, KLMN and OPQR. Once all markers have been glued on the boxes you can proceed to the last step.

STEP4: Assembling the calibration structure.

To assemble the calibration structure, start by placing the OPQR box on the ground. Add on top box KLMN exactly as the following image denotes, paying attention so that the corners of the two boxes - highlighted in the image below - align.

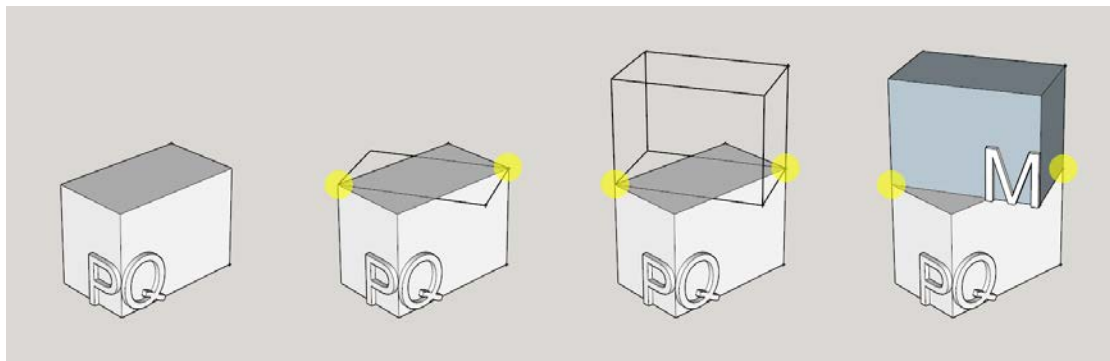

Image 12 Step by placement of box KLMN on box OPQR.

Proceed in the same way by adding box GHIJ on top and finish by positioning box ABCD. These steps are described in the following image:

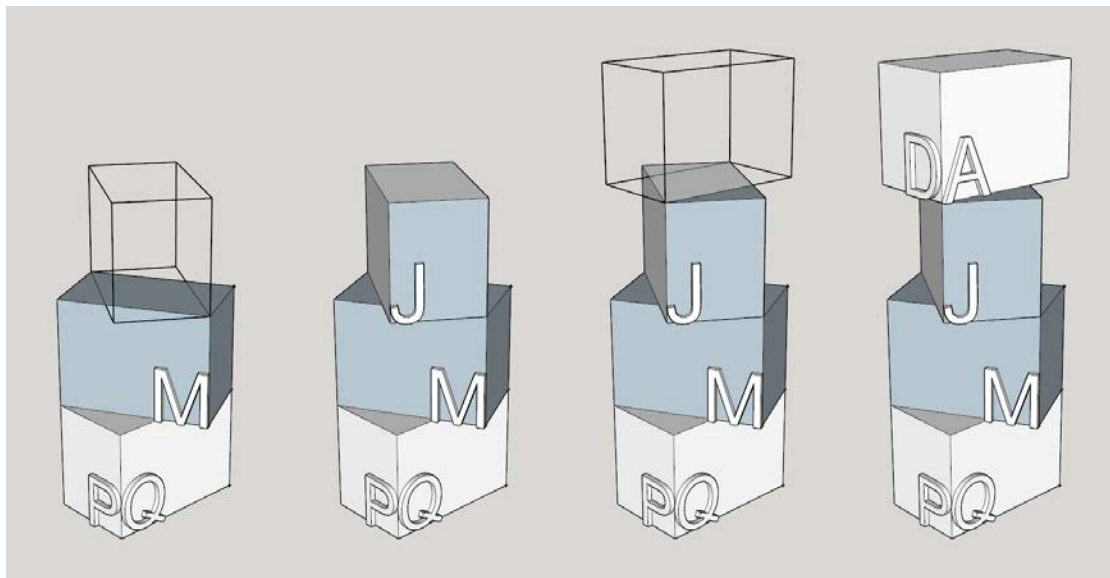

Image 13 Step by step placement of the remaining two boxes: GHIJ and ABCD.

The resulting structure should look like this:



Image 14 The assembled calibration structure.